

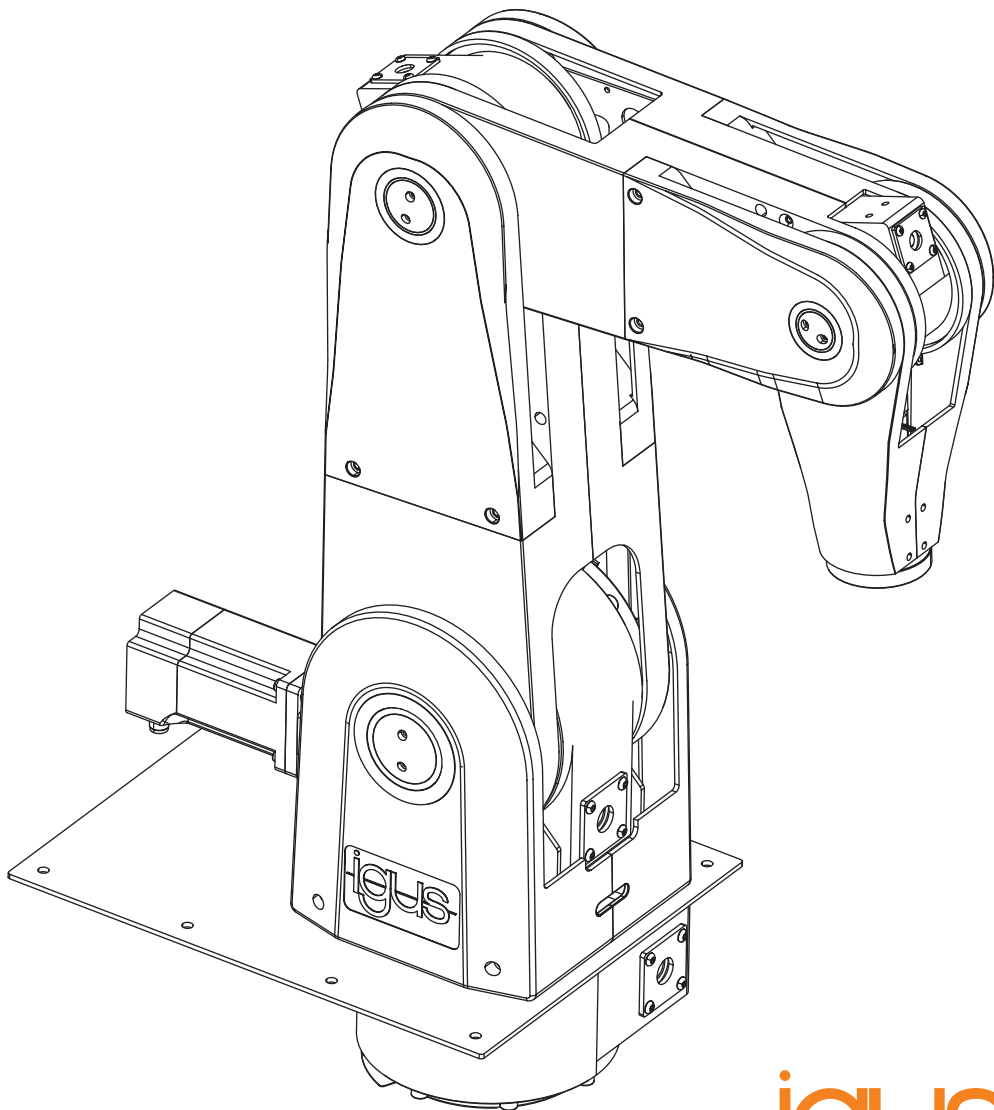

Technische Dokumentation Technical documentation
roboLink®

DP VERSION



Technische Daten Technical data

Positioniergenauigkeit accuracy	+/-1	[mm]
Reichweite reach 5 DOF 4 DOF	790 620	[mm]
Max. Traglast max. payload 5 DOF 4 DOF	3	[kg]
Nennreichweite nominal working range	450	[mm]
Dynamik mit dynamics with 500 [g]	min. 7	Picks/min*
Eigengewicht mass 5 DOF 4 DOF	22,4 21,4	[kg]
Mit und ohne integrierte Steuerung with and without integrated control**		
Schrittmotor NEMA23 XL stepper motor Nema 23 XL with	max. 24/48 [V] max. 4,2 [A]	[V] [A]
Leitungslänge Cable length	4	[m]
Leitungslänge Handheld (optional) Cable length handheld (option)	1,5	[m]
Roboter Standardfarbe Robot standard colour		
Stromversorgung Power supply	230 VAC, 50-60 Hz	

Maximale Traglasten und Präzision in Abhängigkeit von Position und Geschwindigkeit.
Sprechen Sie uns gerne an.

Max. payload and accuracy in relation to position and speed.
Please get in contact with us.

** Integrierte Steuerung mit Schaltschrank
integrated control system with switch cabinet



Mehr Informationen auch zu anderen
Steuerungslösungen unter:

www.igus.de/roboLink/roboter-steuerung

More information about control systems at:

www.igus.eu/roboLink/robot-control-system

* Definition Pick definition pic



minimale Lebensdauer
min. service life

Nutzlast in (g) mass in (g)	Zyklusanzahl in mio. service life in millions cycle
100	3
500	2
1000	2
3000	1

Getestete Lebensdauer mit definierten Pick
unter Laborbedingungen im Nennarbeitsbereich.
Tested service life for the defined pic within the
nominal working range

Zyklusanzahl in mio.
Service life in millions cycle

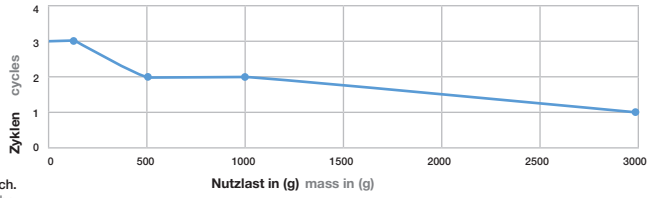

5 DOF

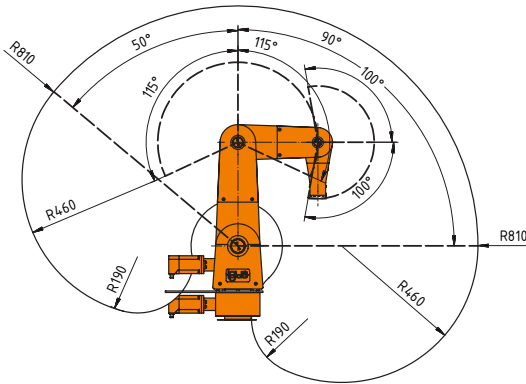

4 DOF

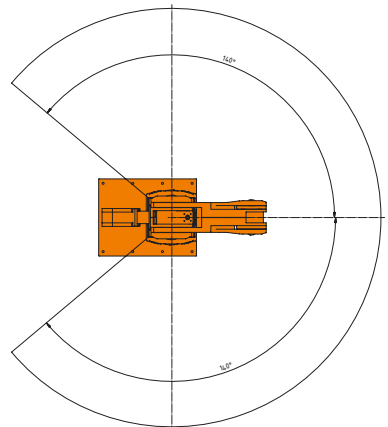
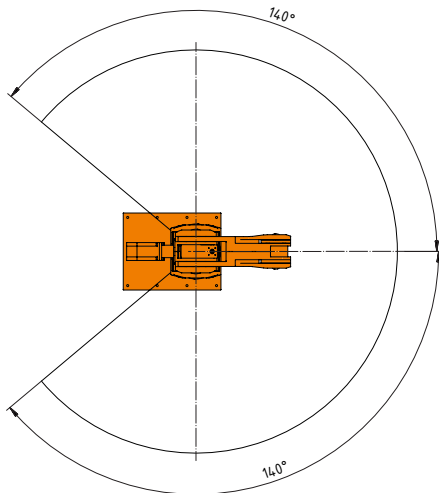
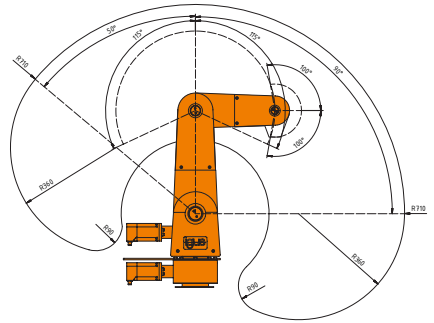

Anschlussmaße Connecting dimensions

Artikelnummer MR-50-BX-01
Part No.

Beschreibung Roboter Grundplatte
Description robot ground case

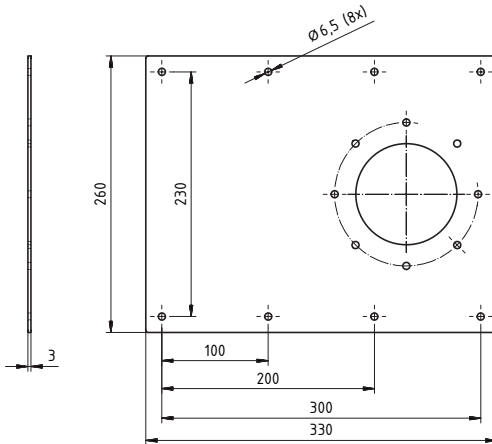

5 DOF Version

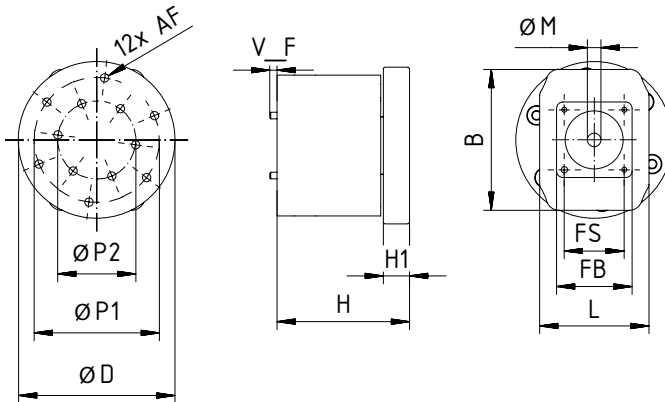

Abmessung in [mm] Dimension in [mm]

Art.-Nr.	Part No.	$\varnothing D$	$\varnothing P1$	$\varnothing P2$	AF	V_F	H	$\varnothing M$	FS	FB	L	B	H1
RL-S-17-N11-00-28-020K0		60	48	30	M4 x 8	M2,5 x 2,75	50,75	5	23	29	42	54	10

Zubehör Accessories

Greifadapter Gripping adapter 4 DOF Version

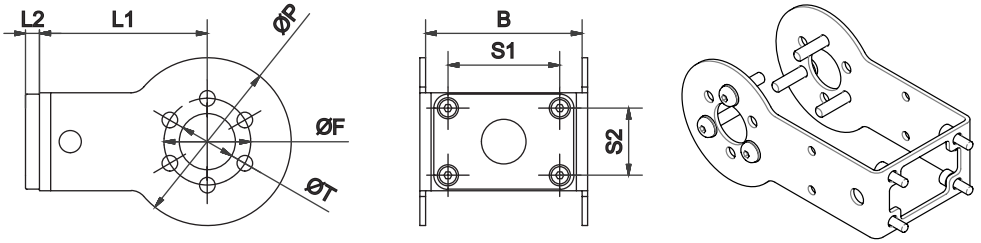

Abmessung in [mm] Dimension in [mm]

Art.-Nr. Part No.	L1	L2	S1	S2	B	ØP	ØF	ØT
RL-DC-20-GRI-90-01-NA*	90	5	40	24	56	60	31	20

*Anschlusselement für 4 DOF robotlink® Mounting bracket for 4 DOF robotlink®

Linearachse für Roboter Linear system for robots

Artikelnummer ZLW-S-4811999-180511
Part No.

Beschreibung Linearachse zur Positionierung der Roboterkinematik, basierend auf ZLW-20200, Zahnriemenachse mit Motor und Getriebe, NEMA 34 mit Encoder.
Description Linear system for robot positioning, based on ZLW-20200, toothed belt axis with gear and NEMA 34 stepper motor, stroke up to 5,500 [mm]

Hublänge bis zu 5.500 [mm]
 Linear system for robot positioning, based on ZLW-20200, toothed belt axis with gear and NEMA 34 stepper motor, stroke up to 5,500 [mm]

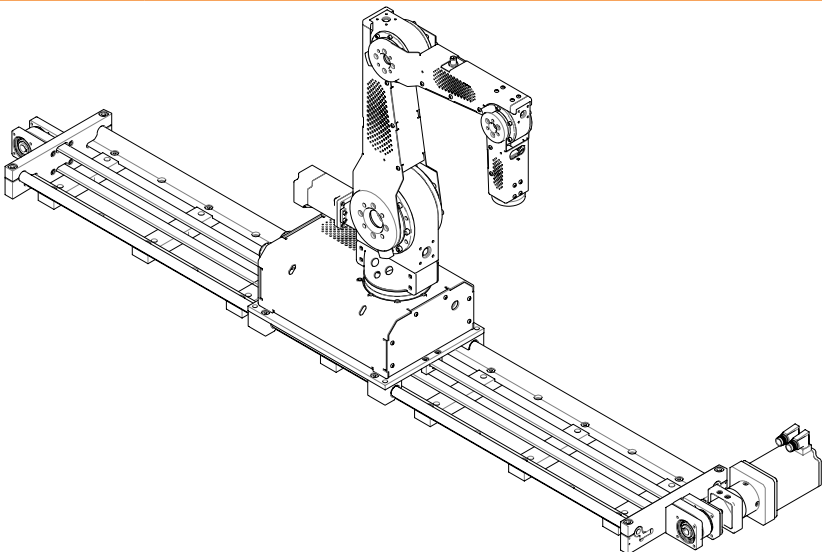

Zubehör Accessories

Unterbau für robolink DP Base unit for robolink DP

Artikelnummer RL-DP-5532-BX
Part No.

Beschreibung Unterbau für Tisch Montage robolink
Description Base unit for table mounting

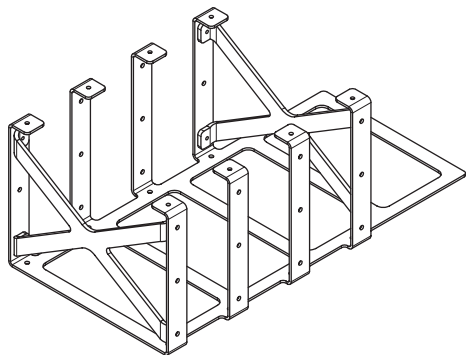
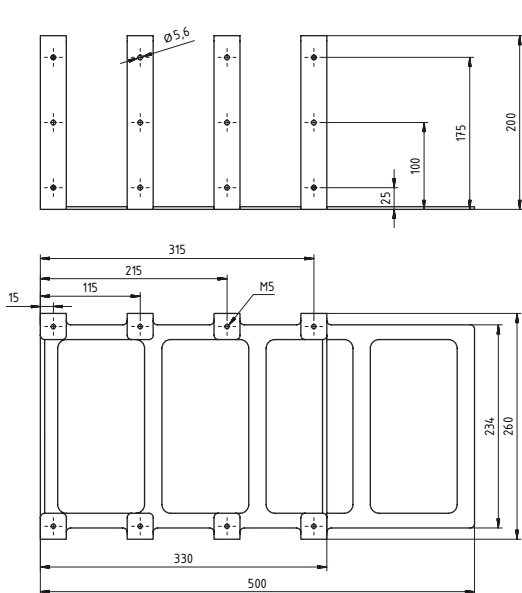



RL-D-20-HH-01

2x



RL-D-20-TT-KL-AR

1x



NOR-20959

2x

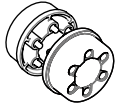

RL-D-20-SRA-KL-RR

2x



RL-D-WW-31-38-A180-AA

1x

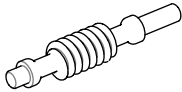

RL-D-WS-31-38-AA

1x

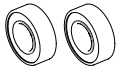

NOR-20947

2x

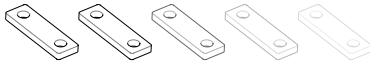

NOR-20629

6x

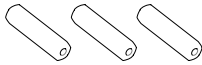

RL-D-20-DB-30-01

3x

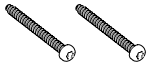

NOR-20140

2x



RL-MAT0155

12x



NOR-20136

12x



NOR-20646

12x

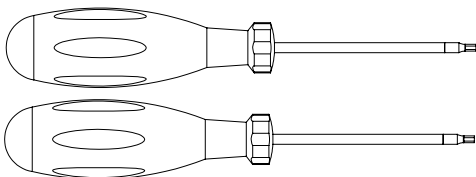

TX10

TX15



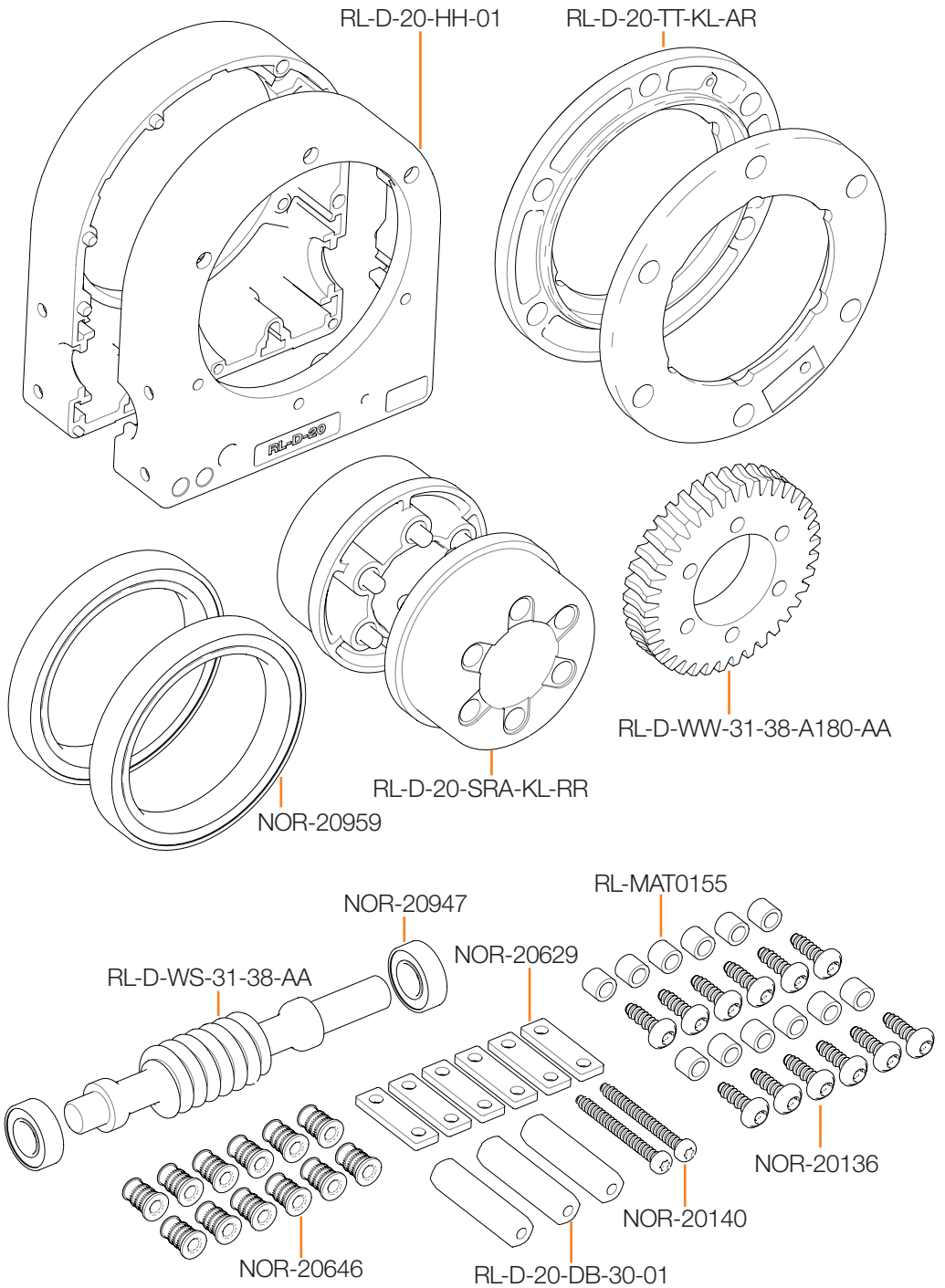

1

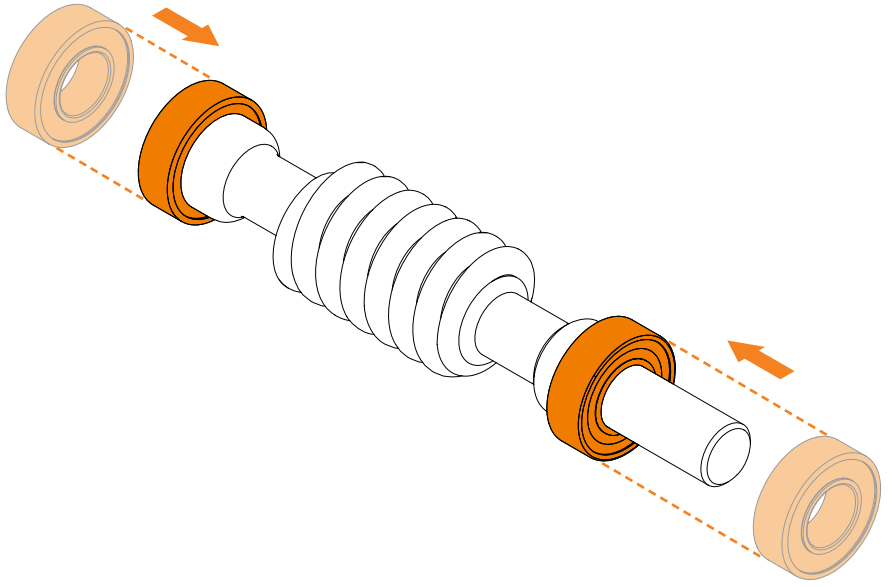

2

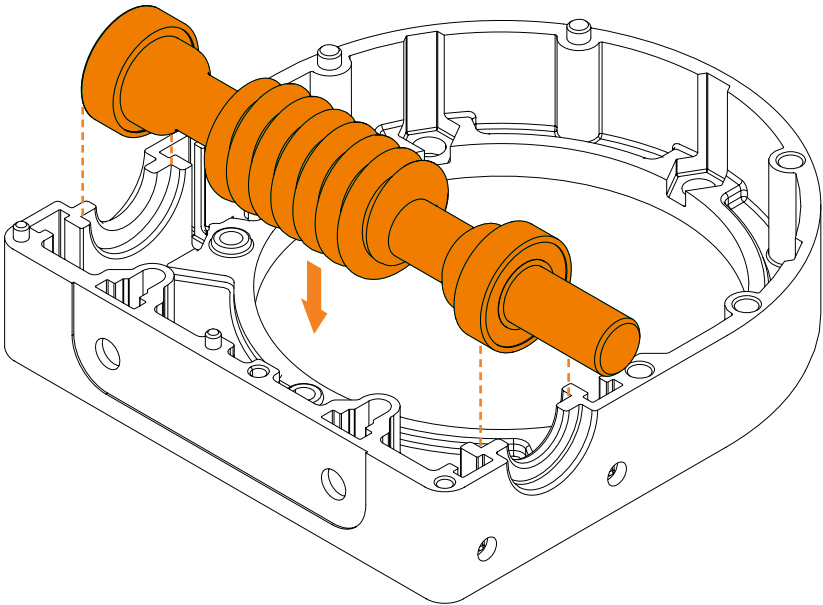

3

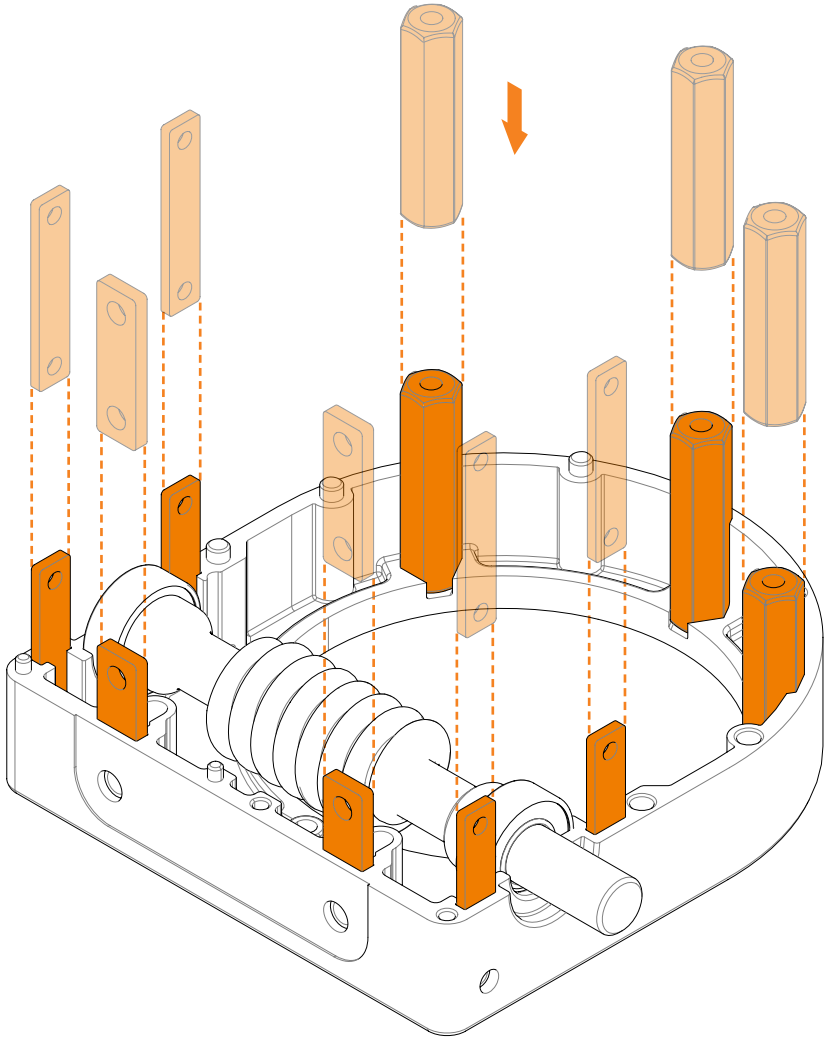

4

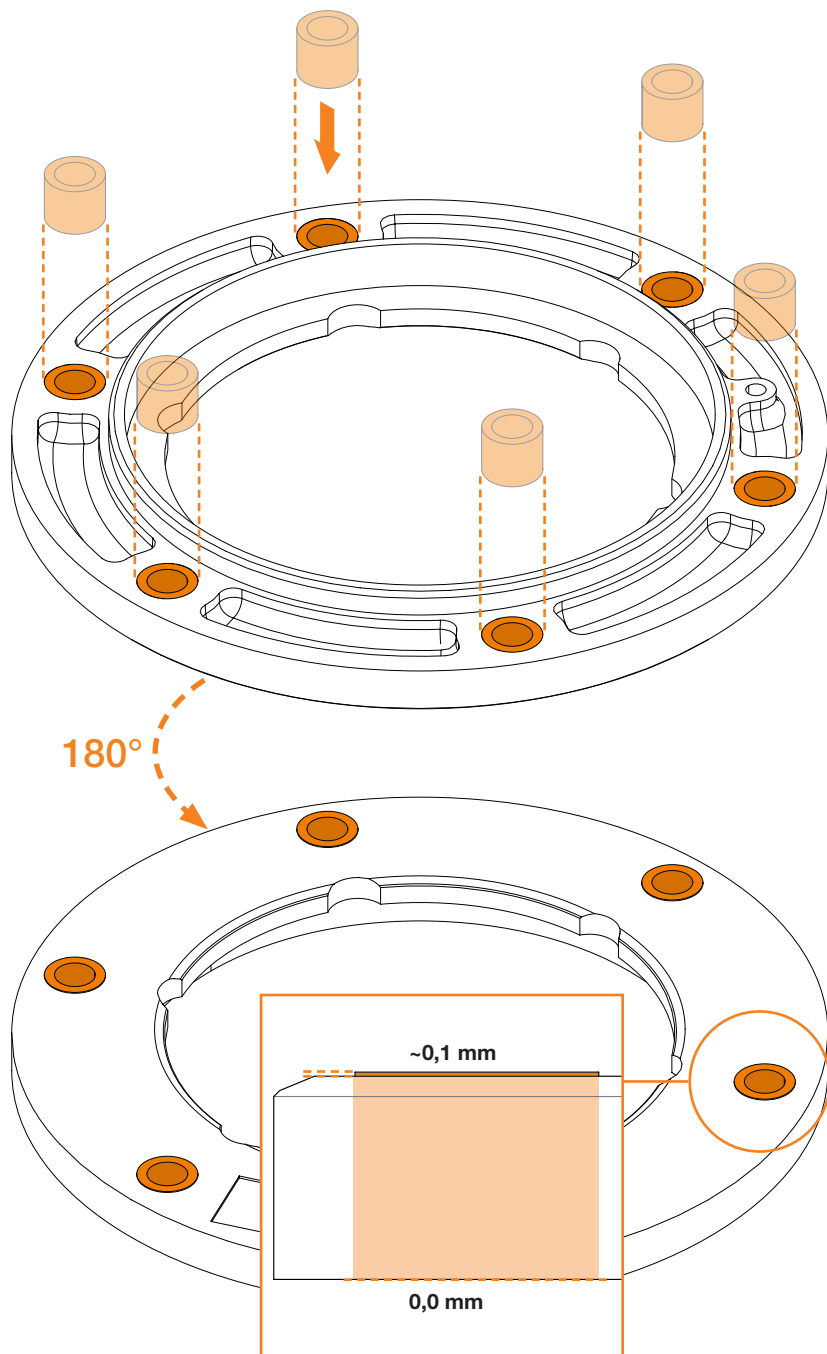

5

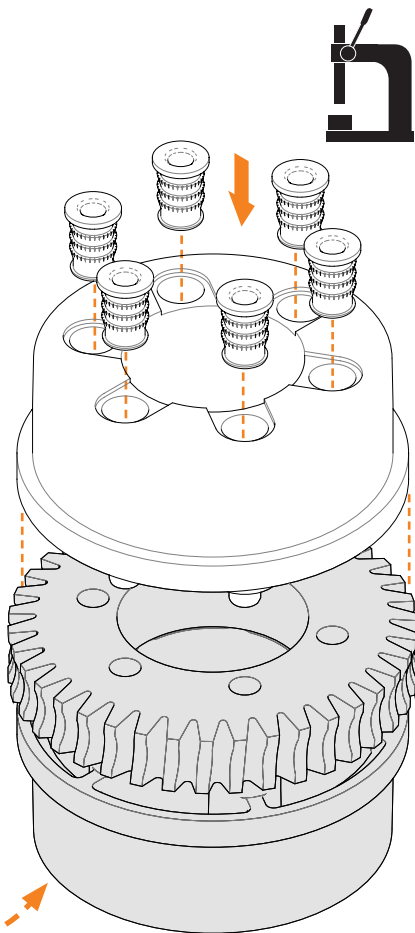
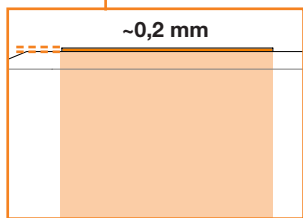
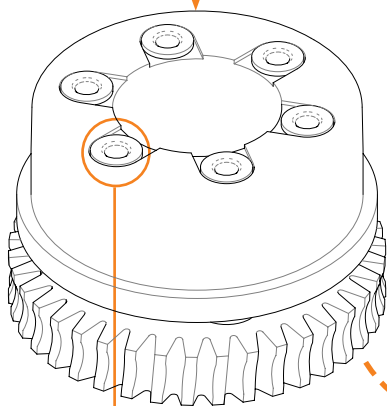
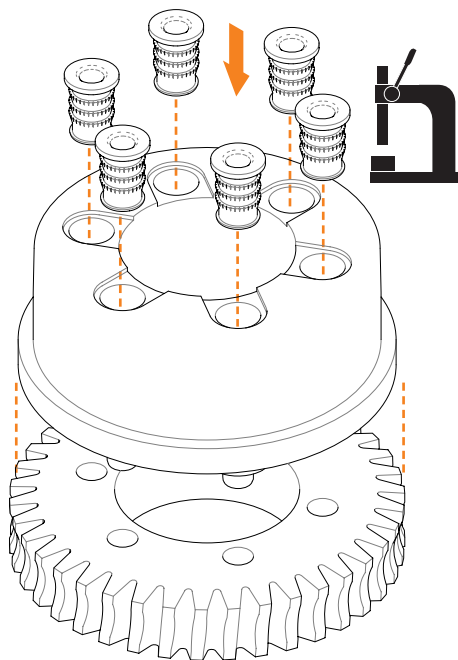

180°



Einpresshilfe nutzen
Use press-fit tool

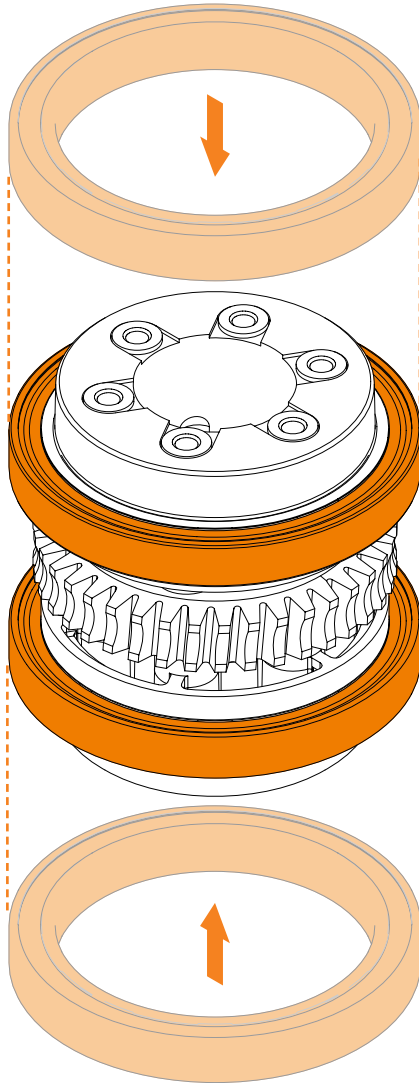

7

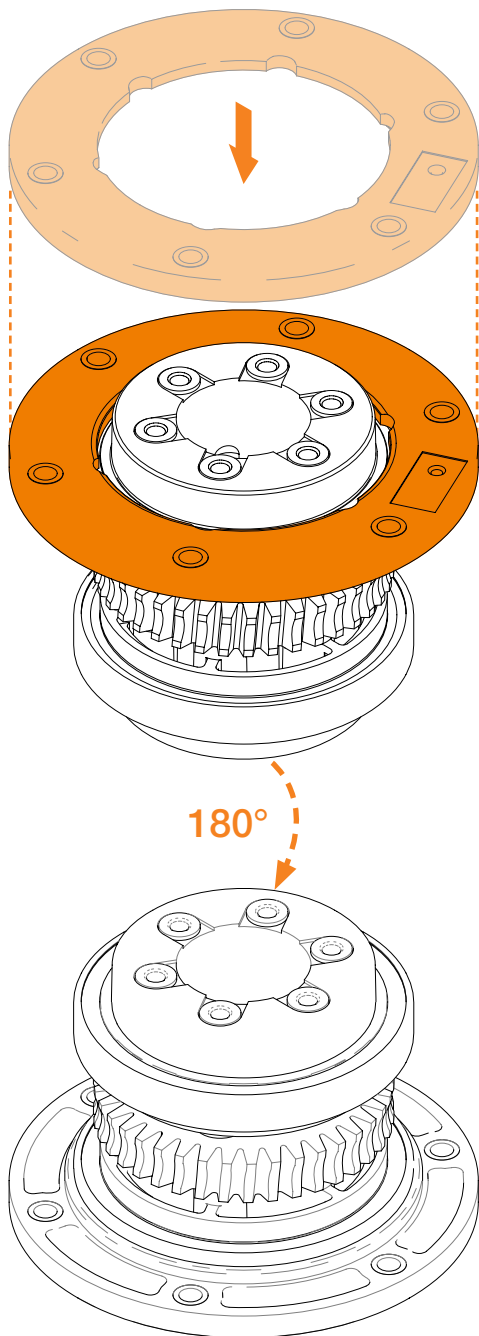

8

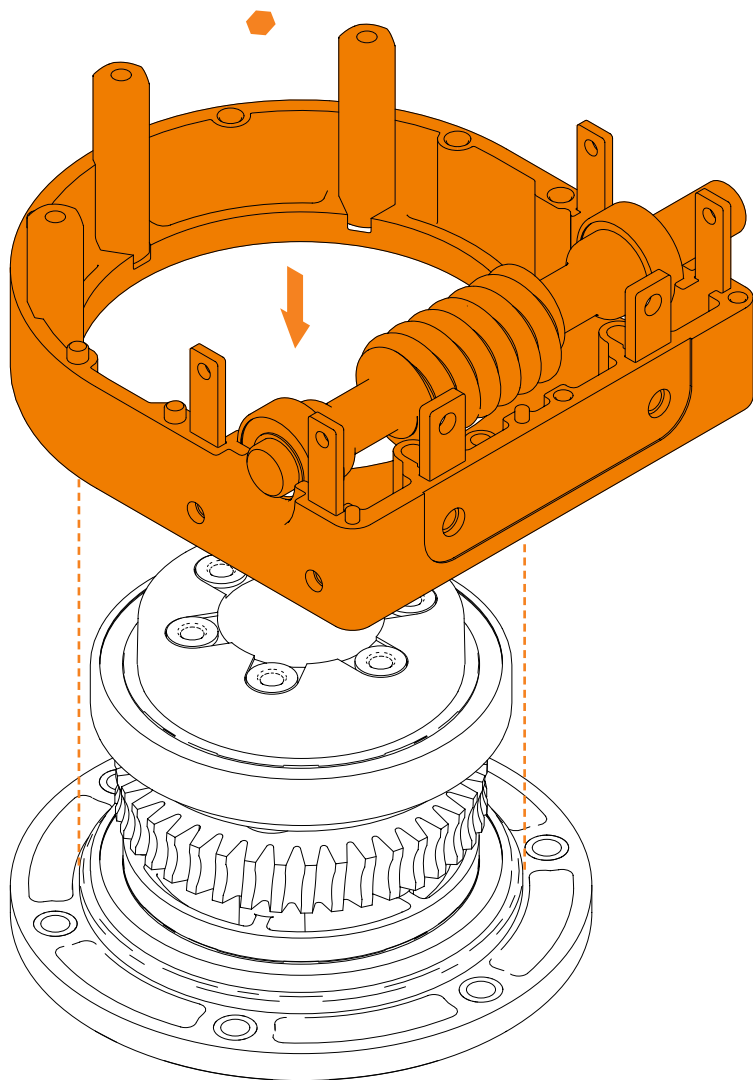

9

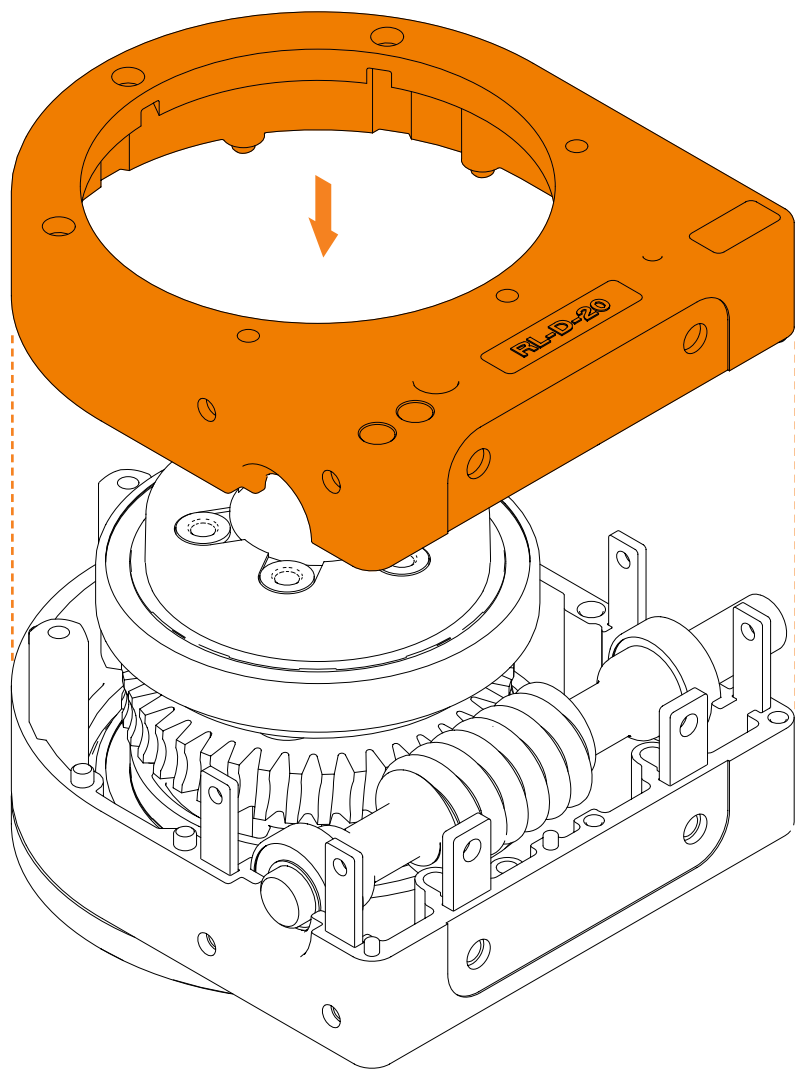

10

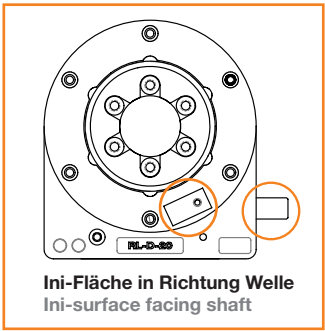

Ini-Fläche in Richtung Welle
Ini-surface facing shaft

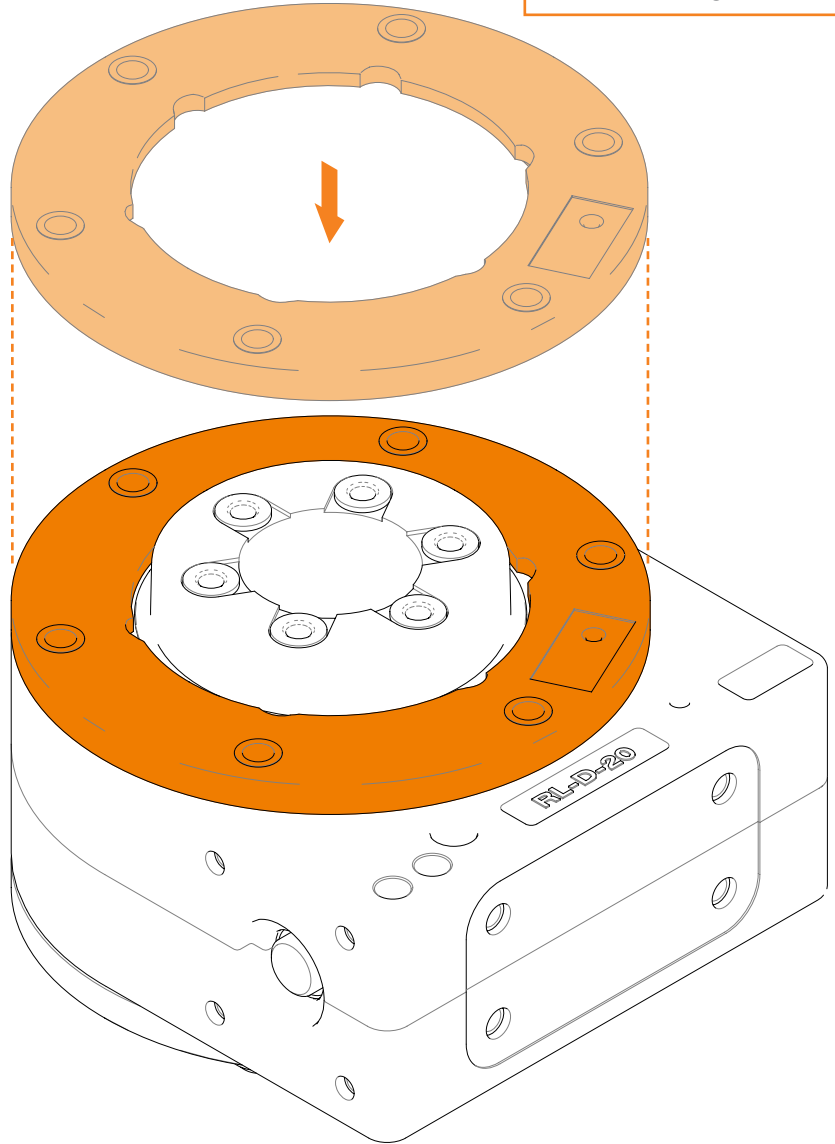

11

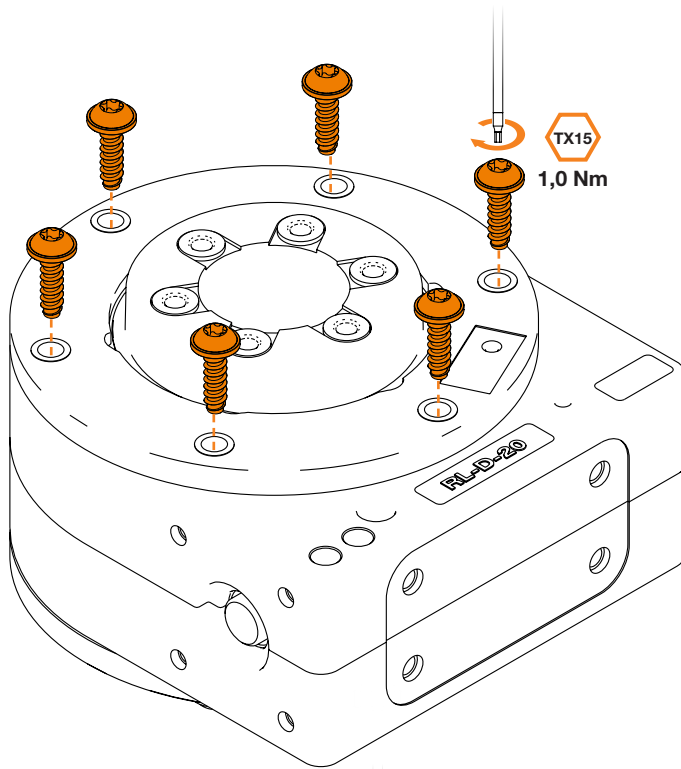

12

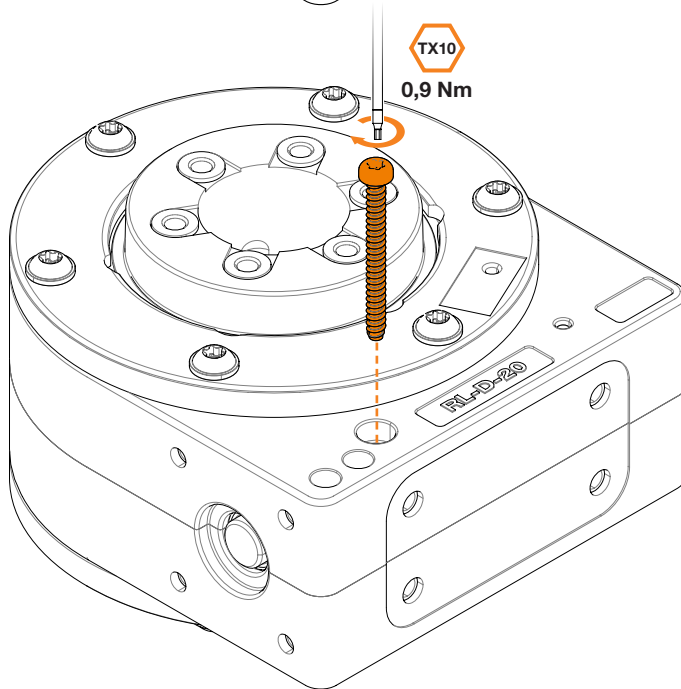

13

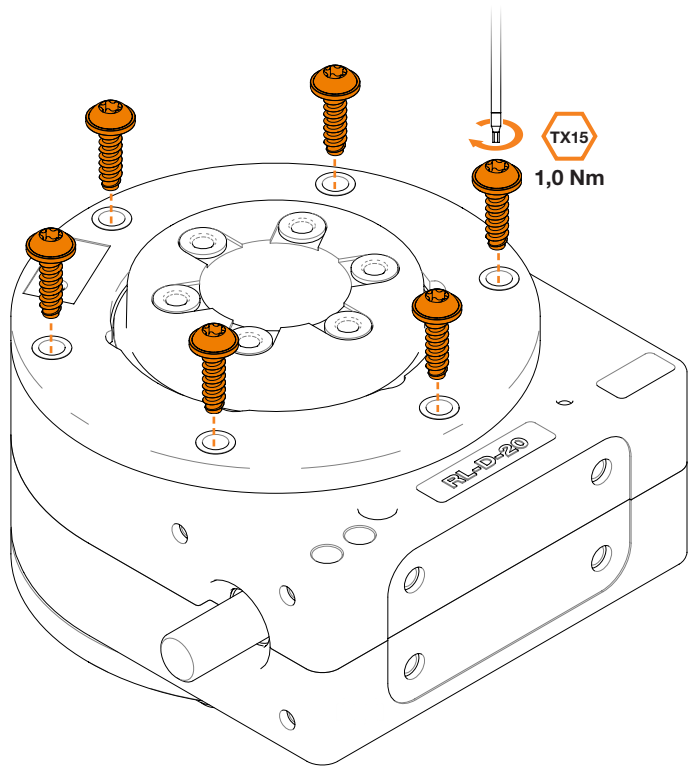

14

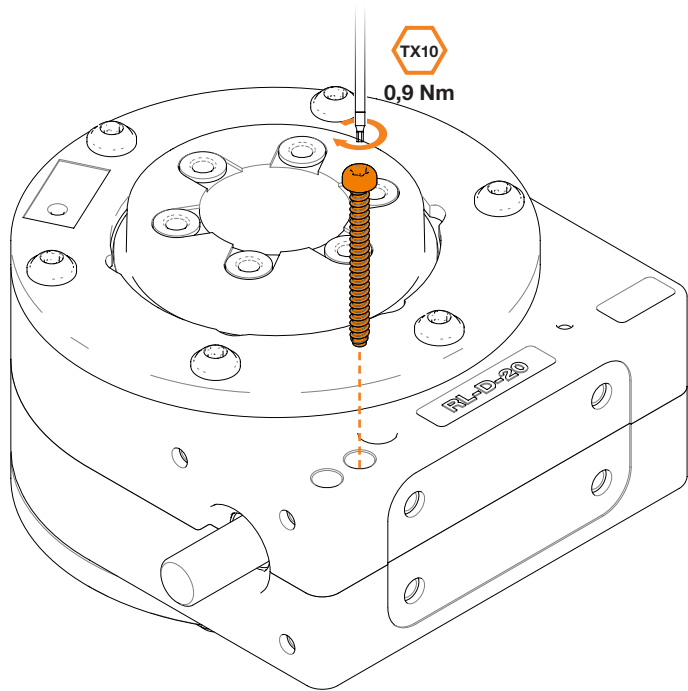

15

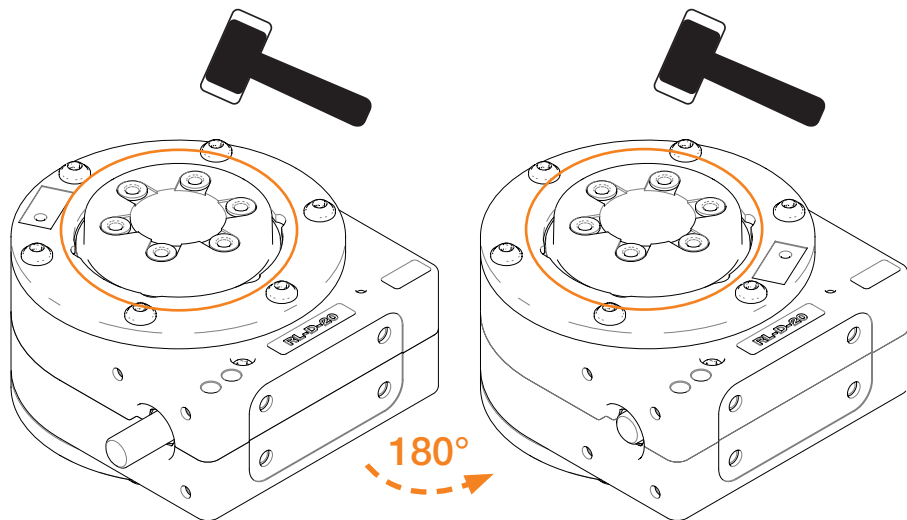

16

control

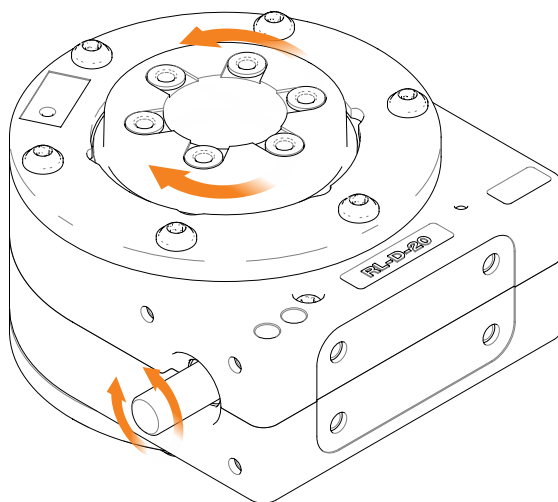



iglus® GmbH
Spicher Str. 1a
51147 Köln Cologne
Tel. +49 2203 9649-145
Fax +49 2203 9649-334
info@iglus.de
www.iglus.de
www.iglus.eu

© iglus® GmbH

Herausgeber ist die iglus® GmbH, Deutschland
Published by iglus® GmbH, Germany
MAT0074623.25 Stand Issue 08/2021
Technische Änderungen vorbehalten
Subject to technical alterations